

CliniLever® Wall Top Assemblies with 150mm Handles

Specification Data Sheet



Features

- Suitable for retro fit to existing wall breach.
- Contra-rotating handles for easy use.
- Smooth round design to facilitate easy cleaning and help reduce dirt and bacterial growth.
- Chrome plate finish for easy cleaning and added durability

To Specify

The AS/NZS 3718 WaterMark approved CliniLever® Wall Top Assemblies, are supplied with 150mm long lever handles and finished in a bright chrome plate:

Code:

TCWTC150PC - Chrome Plated CliniLever® Wall Top Assembly, 150mm Lever Handles, Ceramic Disc (Pair)

TCWTJ150PC - Chrome Plated CliniLever® Wall Top Assembly, 150mm Lever Handles, Jumper Valve (Pair)

TCWTC150HC - Chrome Plated CliniLever® Wall Top Assembly, 150mm Lever Handles, Ceramic Disc (Hot)

TCWTJ150HC - Chrome Plated CliniLever® Wall Top Assembly, 150mm Lever Handles, Jumper Valve (Hot)

TCWTC150CC - Chrome Plated CliniLever® Wall Top Assembly, 150mm Lever Handles, Ceramic Disc (Cold)

TCWTJ150CC - Chrome Plated CliniLever® Wall Top Assembly, 150mm Lever Handles, Jumper Valve (Cold)



A family
owned
Australian
business



galvinspecialised
commercial taps + fixtures

Construction

The wall top assembly flange and handle are made of solid brass. Quick action SBA's includes brass jumper valve components or ceramic disc operation, with a red and blue indicator button on a lever action handle.

Performance Standards & Approvals

- AS/NZS 3718 – WaterMark



Typical Dimensions

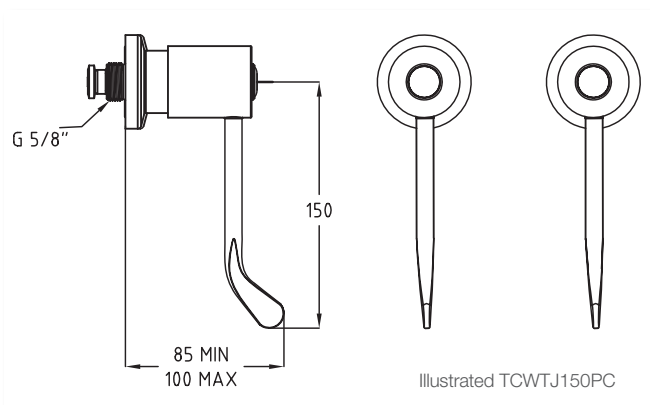

Technical Information

- Inlet: G 5/8"
- Operating temperature range: 5 - 80°C
- Operating pressure range: 50 - 500kPa

Maintenance & Cleaning

Galvin Specialised products should be cleaned with a soft damp cloth using only mild liquid detergent or soap and water. Do not use cleaning agents containing a corrosive acid, scouring agent or solvents. Do not use cream cleaners, as they are abrasive and may scratch the surface and remove markings. Use of unsuitable cleaning agents may damage the surface. Any damage caused in this way will not be covered by warranty.

Regular maintenance should be carried out in accordance with the installation and troubleshooting guides provided with the product, relevant Australian Standards, local authorities and state codes.

Warranty

Galvin Specialised products are covered under our Manufacturer's Warranty at www.galvinengineering.com.au. Galvin Specialised products must be installed in accordance with the installation instructions and in accordance with AS3500 and the PCA, relevant Australian Standards and local authorities applicable to product being installed. Water and electrical supply conditions must also comply to the applicable national and/or state standards, failing to comply with these provisions may void the product warranty and affect performance of the product.

Whilst all reasonable care has been taken in compiling the information in this document, the designs, dimensions and products shown are indicative only and should not be relied upon without our prior approval. Due to our policy of continuous development, we reserve the right to alter any details of specifications or products without notice. All information, drawings, technical specifications and product designs remains the property of Galvin Engineering Pty Ltd.

410 Victoria Rd, Malaga, WA 6090
 P: +61 (0)8 9249 5900
 F: +61 (0)8 9249 5916
sales@galvinengineering.com.au
www.galvinspecialised.com.au

ABN: 78 008 719 382

PERTH | SYDNEY | MELBOURNE | BRISBANE | ADELAIDE

A business unit of

GalvinEngineering
 the mark of reliability

